

Superior
& **Exciting Service**
Challenge!

sec
e-beam pioneer

Superior Service

X-RAY INSPECTION
SYSTEM
X-eye Series

Exciting Challenge!

South Korea - Headquarters

111, Saneop-ro 155beon-gil, Gwonseon-gu, Suwon-si, Gyeonggi-do, Korea 16648
Tel +82-31-215-7341 Fax +82-31-215-7343 E-mail secmaster@seceng.co.kr
www.seceng.co.kr

China-Shenxhen Office

Room109&111, Building B, Huachuangda Culture and Technology Industrial Park, Haihui Road, Xin'an Street, Bao'an District
Tel +86-755-273299696 Fax +82-755-27399696 E-mail wenri@seceng.co.kr
www.seceng.co.kr/CHI

Vietnam-Office

Can ho so 907, A2, The Garden, Khu do thj My Dinh, phuong My Dinh 1, quan Nam Tu Liem, thanh pho ha Noi
Tel 070-7705-7341 Email leejh@seceng.co.kr
www.seceng.co.kr/ENG



SEC is the best inspection system company developing & selling industrial X-ray inspection system and SEM(Scanning Electron Microscope). We develop and offer linear accelerator and semiconductor packaging system for LCD driver IC as well. Since established in 1991, based on over 20 years of accumulated technical know-how, we have been continuously developing backbone of e-beam inspection equipment in Korea. SEC has its own competitiveness against global companies by continuously localizing X-ray generator and developing new technologies. Also, go through continuous technology development and aware of the current economic and technological environment, we will continue to constantly challenged to expand business area and move into the future Global Leader.

E - beam pioneer

Specialized corporation in E-beam technology, leading the nano era

Superior Service & Exciting Challenge!

Seeking the **best!** Walking the right **path!** Keeping the **faith!**

"Superior Service & Exciting Challenge!"

From 21th century, we build our vision "Superior Service & Exciting Challenge!" that pursue our challenge spirit as well as punctuality.

SEC will strive to keep the principle of providing excellent products with reasonable price at the right time and to satisfy customers with best service.

History

10 Million dollars awarded

tower of export

- **2017 ~**
Launched Linear Accelerator
- **2012 ~ 2016**
Developed Hybrid X-ray generator
Attains 1,000 sales of X-ray Inspection System
- **2009 ~ 2012**
Developed 2D & CT In-Line Inspection System
Developed Nano-Focus
- **2006 ~**
Localize X-ray generator (One and only in domestic)
- **2000 ~ 2005**
Developed X-ray Inspection Systems
- **1991 ~ 1999**
SEC Engineering Established

X-ray

Specification



X-eye 5100F



X-eye SF160FCT



X-eye NF120



X-eye 6300



X-eye 6200



X-eye 6100



X-eye 7000BS



X-eye 7000B



X-eye PCT



X-eye 6000POP



X-eye 4000A



X-eye 9000

Model	X-ray Tube	Resolution	Max Power	Table Size (mm)	Detector Resolution	Dimension (mm) W x D x H	3D CT
5100 Series	100kV /200μA	5μm	20W 26W	460 x 340 550 x 550	FPD 2304 x 1300	1,270 x 1,020 x 1,460 720kg	2D ONLY
SF160 Series	160kV /200μA	0.8 / 1μm	32W 80W	460 x 510	FPD 1280 x 1280	1,340 x 1,460 x 1,670 2,000kg	CBCT, OBCT
NF120	120kV /200μA	0.2μm	24W	12inch Wafer	FPD 1944 x 1536	2,380 x 1,450 x 2,120 7,000kg Control Box 600 x 1,250 x 1,030	OBCT, CBCT
6300	160kV /500μA	0.8 ~ 15μm	32W	Max 330x250 Min 50x50	FPD 2064 x 2236	1,360 x 1,880 x 1,700 4,200kg Control Box 640 x 950 x 1,190	OBCT
6200	160kV /500μA	0.8 ~ 15μm	32W	Max 330x250 Min 50 x 50	FPD 1280 x 1280	1,460 x 1,640 x 1,780 2,500kg	2D ONLY
6100	100kV /200μA	5μm	20W	400 x 400	FPD 1280x 1280	1,020 x 1,350 x 1,720 1,500kg	2D ONLY
7000BS	160kV /1,000μA	6μm	48W	300 x 300	FPD 2064 x 1548	1,840 x 1,500 x 1,780 2,500kg	CBCT
7000B	160kV /3,000μA	6μm	80W	650 x 950	FPD 2064 x 2236	2,560 x 1,900 x 2,120 5,500kg	CBCT
PCT	225kV /3,000μA	6μm	675W	500 x 1,000	FPD 4M pixel	2,680 x 1,570 x 2,330 8,000kg Control Box 1,204 x 1,030 x 2,040	CBCT
6000POP	130kV /200μA	6 ~ 15μm	26W	Max 22 x 22 Min 8 x 6	FPD 2958 x 2958	3,080 x 1,730 x 1,920	CBCT
4000A	130kV /200μA	6μm	20W	Max Ø400	FPD 3072 x 3072	1,400 x 1,240 x 810 650kg	2D ONLY
9000 Series	100kV /200μA	5μm	20W	Max 180ppm	FPD 2064 x 1548	1,800 x 1,560 x 2,070 5,000kg	2D ONLY

X-ray Tube

Develop & manufacture one and only X-ray generator in domestic

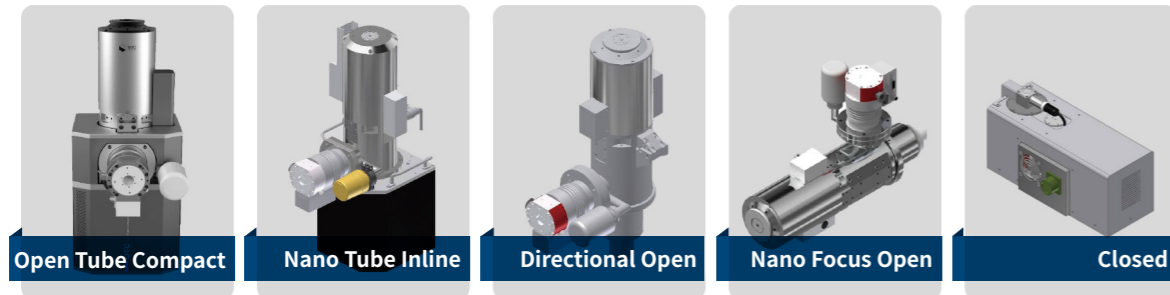

Tube	Voltage(kV)	Current(mA)	Focal Spot(μm)
Open Tube Compact	160	0.2	1
Nano Tube Inline	160	0.5	0.8
Directional Open	160	1	5
	225	3	6
Nano Focus Open	120	0.2	200(nm)
Closed	90 ~ 130	0.8	5
	320 ~ 450	22.5	0.4 ~ 1.0mm

Type	Open Tube	Closed Tube
Vacuum Type	Vacuum pump	Pre-vacuum type
Resolution / Magnification	High resolution & magnification	Lower resolution & magnification than Open Tube
Lifespan	Semi-permanent(Filament replacement)	10,000Hr
Cost	High initial investment cost	Low initial investment cost

Detector

Pixels	Active Area	Resolution	Energy Range	Frame Rate
1152 x 1300 / 1.5M	57 x 64mm	49.5μm	10 to 225kV	20fps
2304 x 1300 / 3M	114 x 64mm	49.5μm	10 to 225kV	22fps
2940 x 2304 / 6M	145 x 114mm	49.5μm	10 to 225kV	5fps
1280 x 1280 / 1.6M	128 x 128mm	99μm	40 to 225kV	30fps
1548 x 1280 / 1.6M	204 x 153mm	99μm	10 to 225kV	20fps
2064 x 2236 / 4.6M	204 x 221mm	99μm	10 to 225kV	30fps
3096 x 3100 / 9.6M	306 x 307 mm	99μm	10 to 225kV	30fps
1000 x 1000 / 1M	204.8 x 204.8mm	200μm	20 to 225kV	30fps
2048 x 2048 / 4M	409.6 x 409.6mm	200μm	20 to 225kV	30fps

Resolution

Geometric Magnification

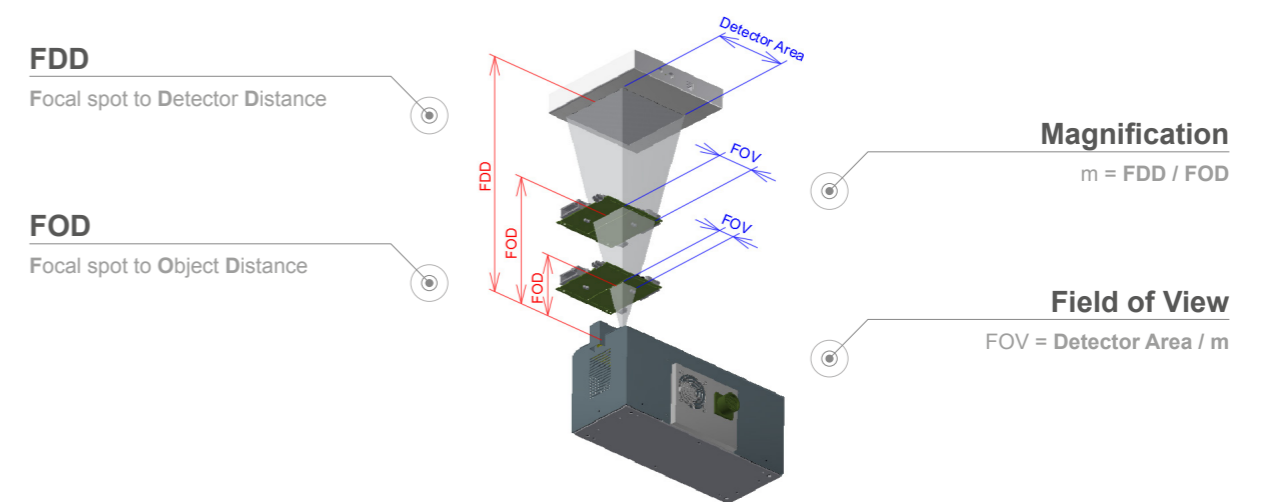

Focal Spot Size

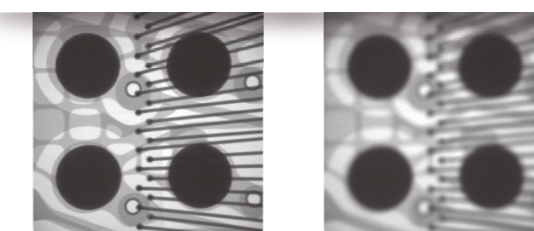
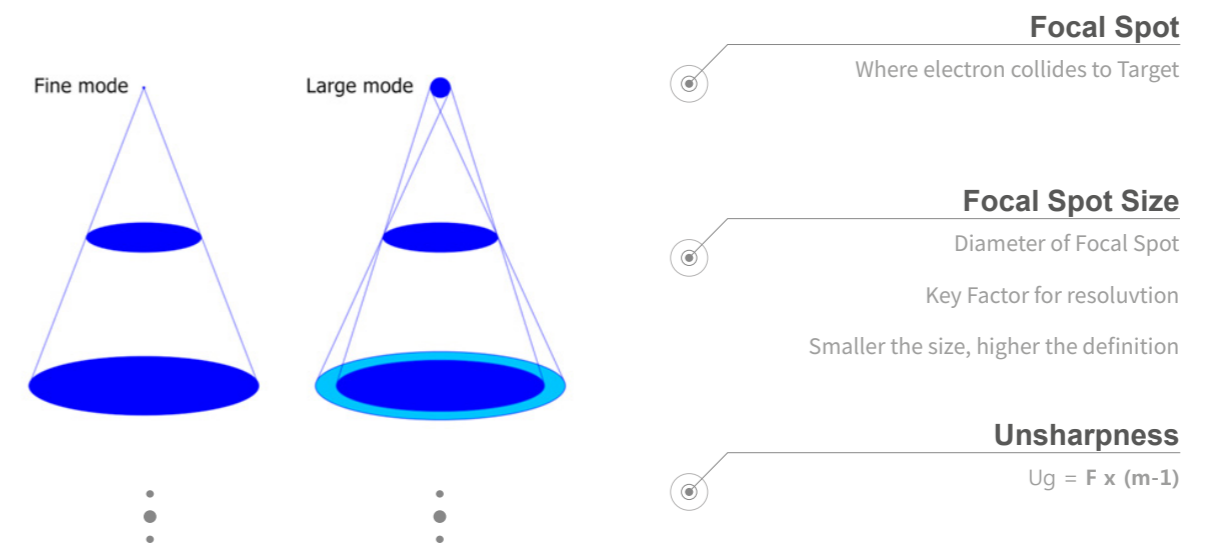

BGA
Focal Spot 5μm

BGA
Focal Spot 50μm

X-ray Equipment Composition

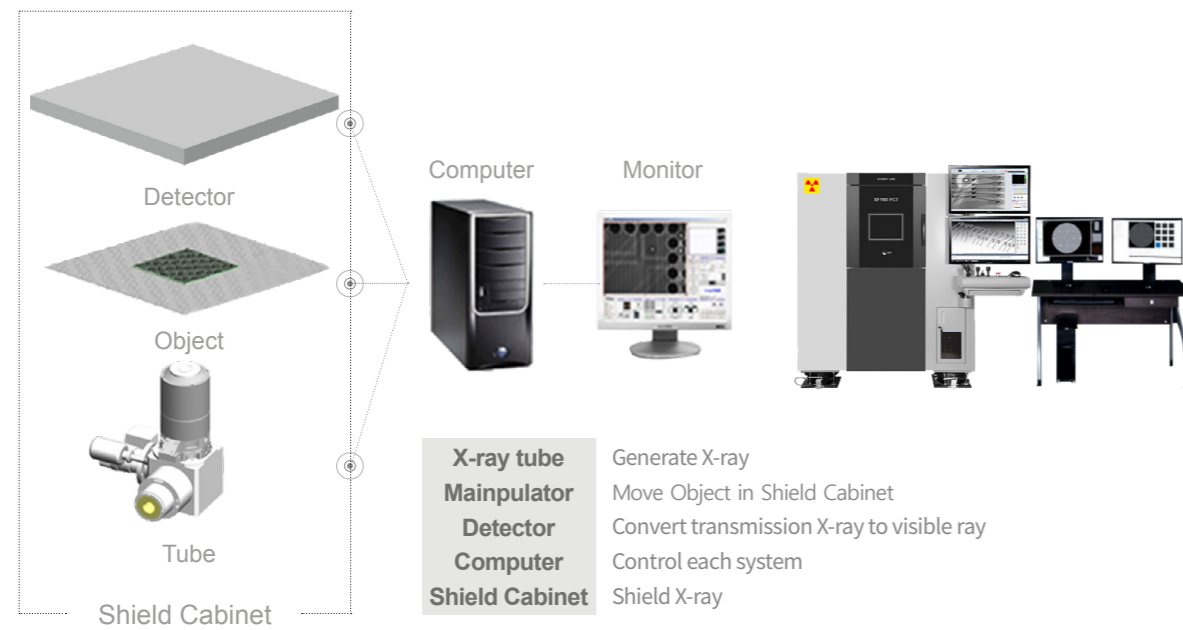

CT Scanning Method

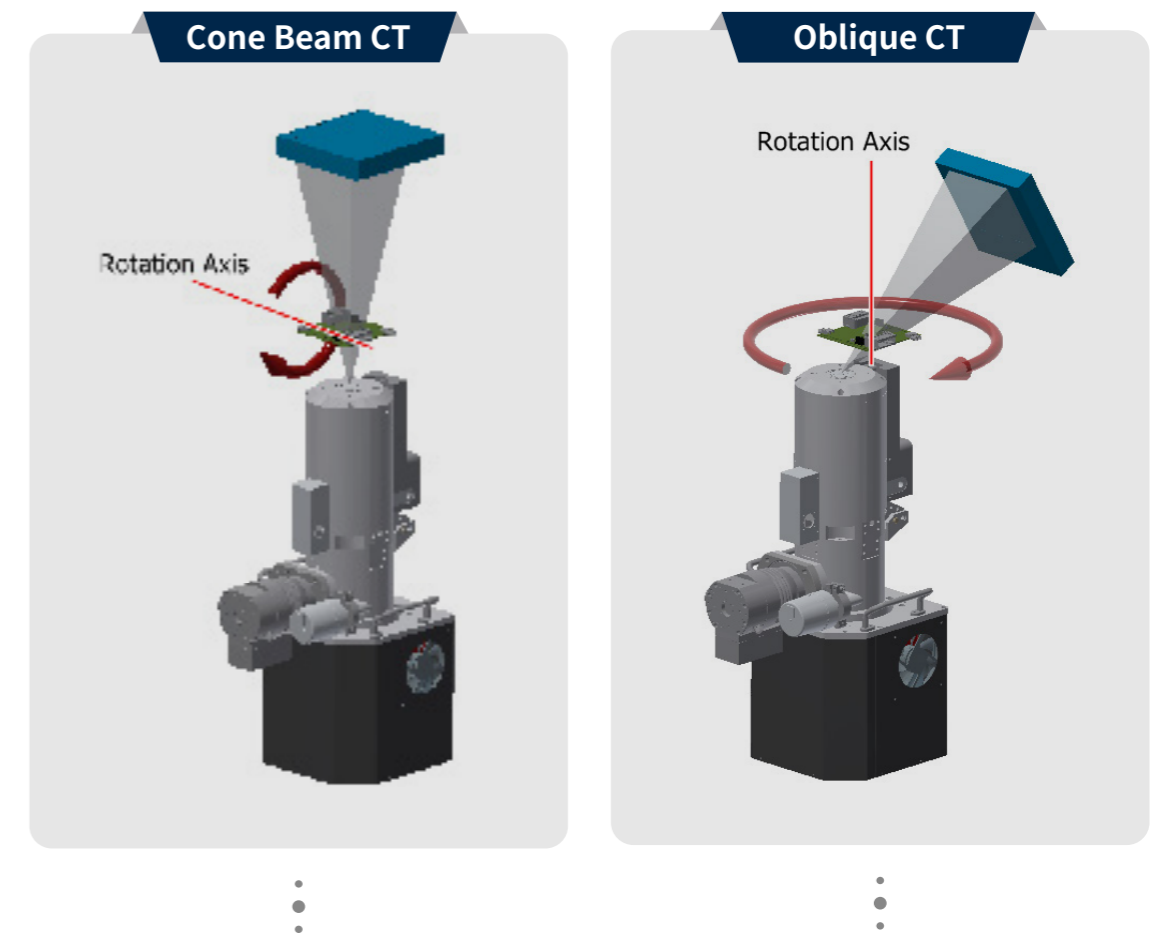

CT Image Process

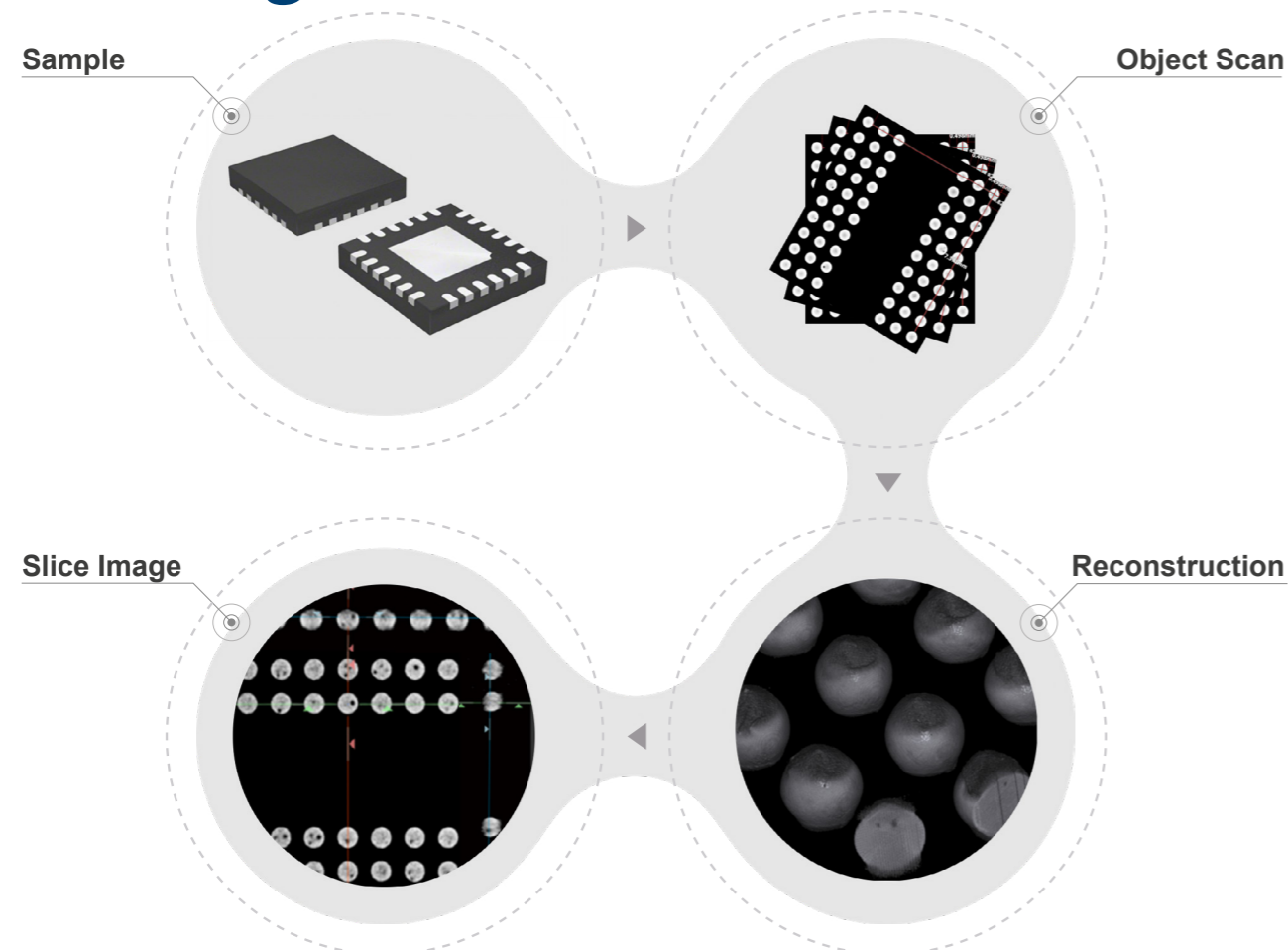

	Cone Beam CT	Oblique CT
Type	Rotation axis is vertical to Beam axis	Rotation axis is sloped to Beam axis
Analysis ability	Optimized to analyze commissure	To analyze overall structure
Sample size	Best for small sample	Best for big sample
Model	X-eye SF160 X-eye 6000 POP X-eye 7000 Series X-eye PCT	X-eye SF160 Series X-eye 6300 X-eye NF120 Series

2D AXI 2D Auto X-ray Inspection

SMT Inspection

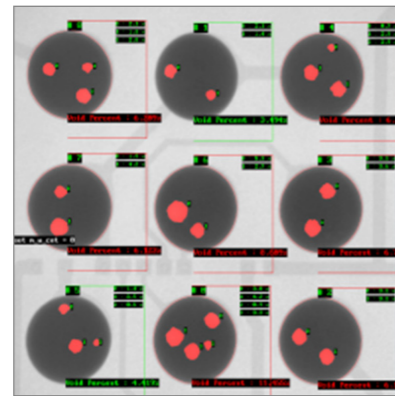
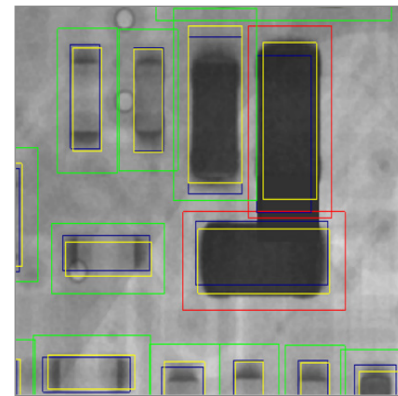

Item	N.G.
BGA	Short, Bridging, Void
Chip	Manhattan, miss align, Short
Tact Time : 0.5 sec / FOV	
Model	
SF 160F	5100F
6100	6200

Battery Inspection

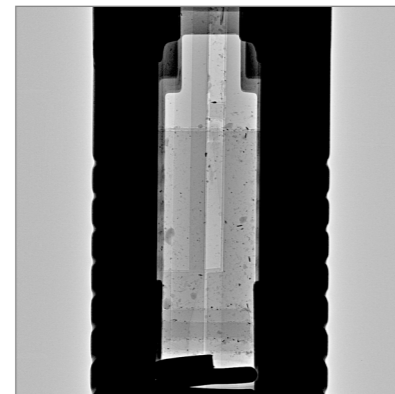
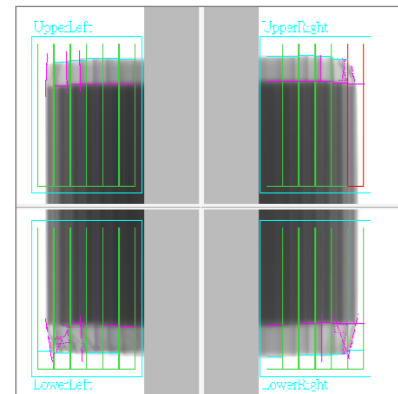

Item	N.G.
Battery	Edge
Tact Time : 0.5 sec / FOV	
Model	
SF 160F	5100F
6100	6200
9000	

Wire Bonding Inspection

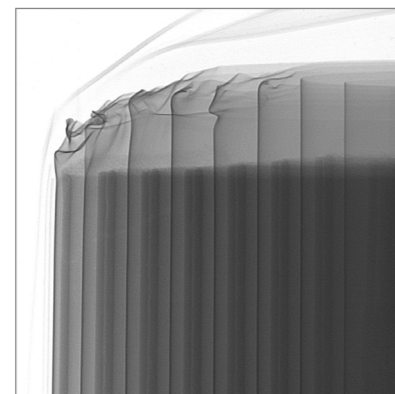
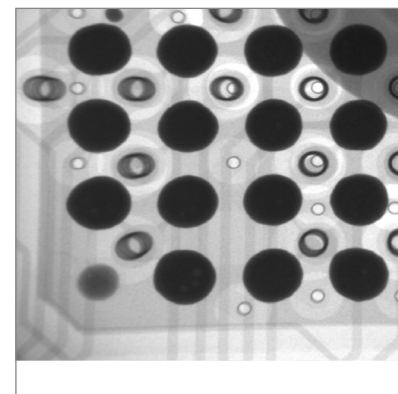

Item	N.G.
Wire Bonding	Sweep, Broken, Double Bonding, Missing
Tact Time : 0.5 sec / FOV	
Model	
SF 160F	5100F
6100	6200

3D AXI 3D Auto X-ray Inspection

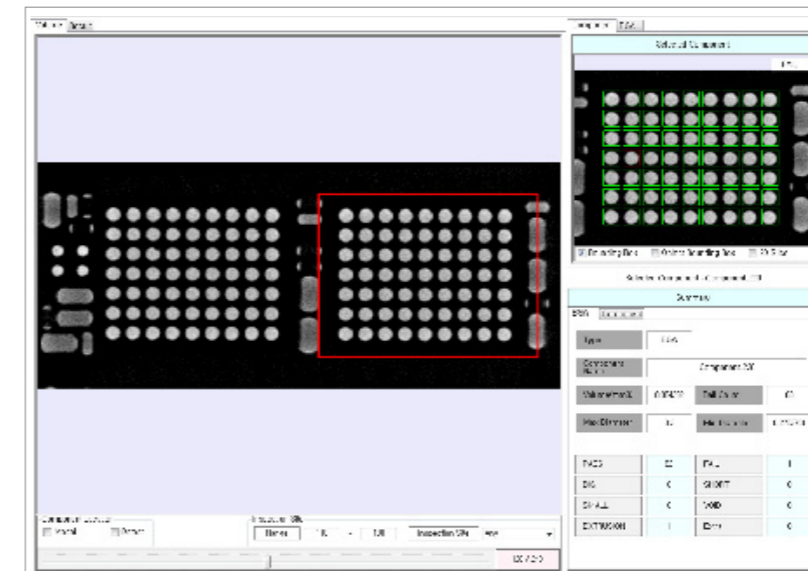

3D inspect by moving along the point user indicated.

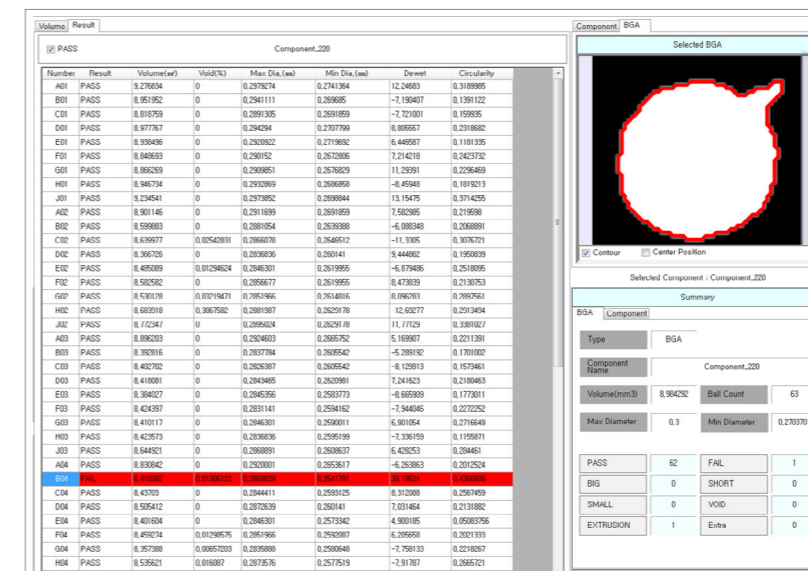

Inspect and check defect image through auto-inspection.

Item	N.G.
BGA	Short, Bridging, Void, Crack
Tact Time : 0.5 sec / FOV	
Model	
6300	6000POP

X-eye 5100 Series

100kV ~ 130kV Micro-focus Closed tube and high-definition Flat Panel Detector are installed and high-resolution image can be gained. Customer convenience is primarily considered in operation and maintenance of the product.

Customization is available because it is specially designed to be add up any necessary functions depending on customer needs with reasonable prices.



- **Non-destructive analysis** of semiconductor, SMT and electron / electric components
- **Inspection S/W is able to be installed for mass production** of SMT and electron / electric components
- **Various convenient functions** - Easy of use

General Product Features	
X-ray Tube	100kV / 200μA (Option 130kV / 220μA)
Min Resolution	5μm
Table Size	460 x 340mm (Option 550 x 550mm)
AXIS	X, Y, Z, Tilt (±50 °)
Detector	2.5 inch FPXD or 5 inch FPXD
Dimension	1,270(W) x 1,020(D) x 1,460(H)mm / 720kg

X-ray image

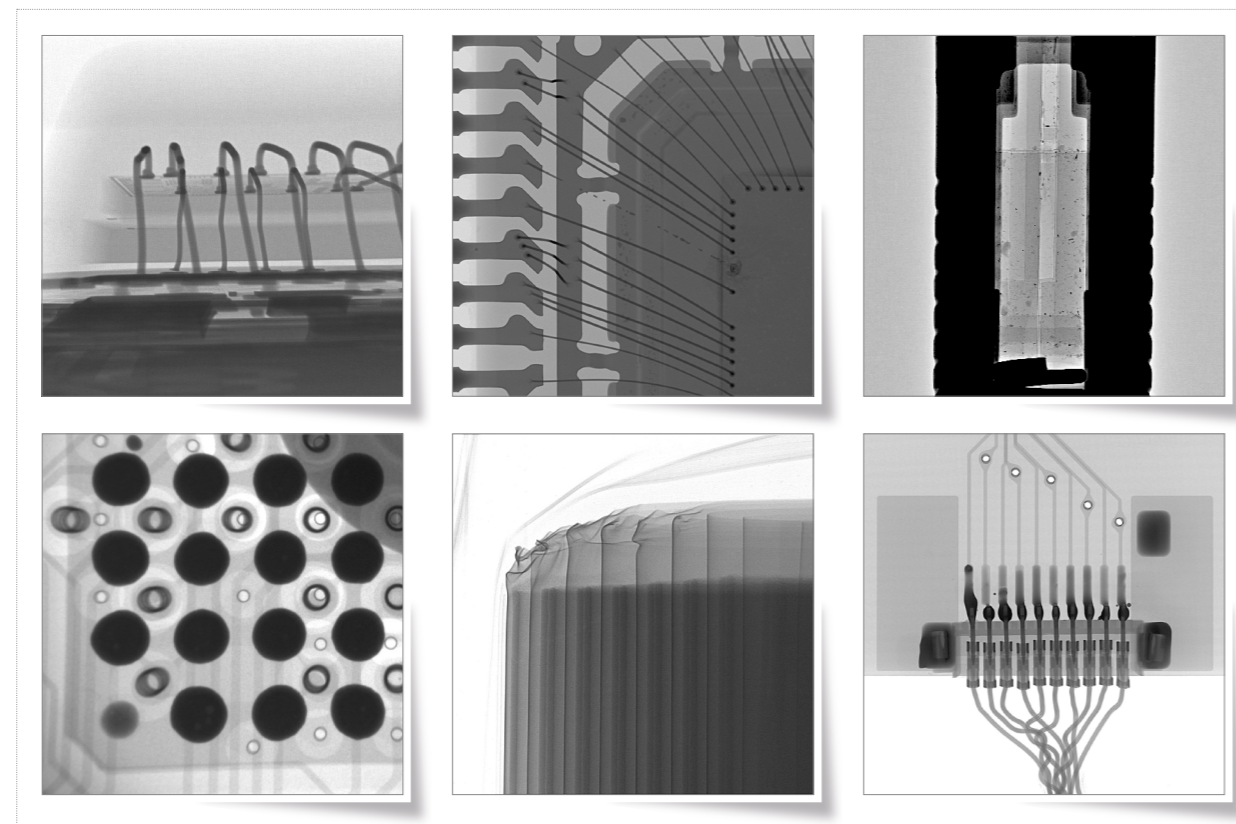

X-eye SF160 Series

High-performance Micro-focus Open Tube with 160kV is installed and fine defects of 1μm are detectable. High-resolution X-ray image can be gained with world best magnification by installing high-price Open Tube as standard. Dual CT function can be purchased additionally, and exact location & size of defects can be detected and analyzed with this function.



- **Non-destructive analysis** of semiconductor, SMT, and electron / electric components
- Hybrid Tube - filament(consumable) **lifespan 10,000hrs**
- Dual CT - **High-quality CT image**

General Product Features	
X-ray Tube	160kV / 200μA (Option 160kV / 500μA)
Min Resolution	0.8 / 1μm
Table Size	460 x 510mm (Option 650 x 550mm)
AXIS	X, Y, Z, Tilt(±70 °),R, Y-aft, Cone beam R
Detector	5 inch FPXD
CT Scan Method	Oblique CT / Cone beam CT
Dimension	1,340(W) x 1,460(D) x 1,670(H)mm / 2,000kg

X-ray image

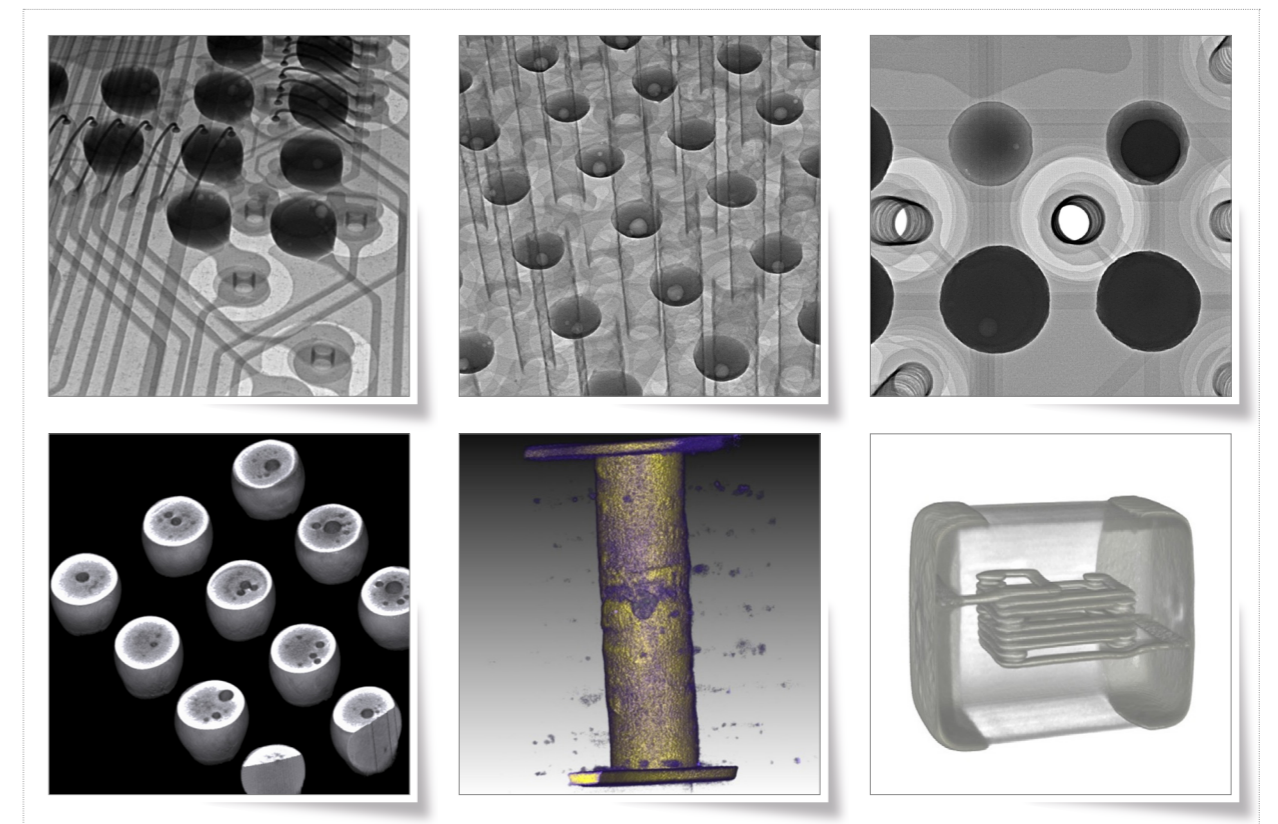

X-eye 6000 Series

Obtain image by Source moving (Tube, Detector)

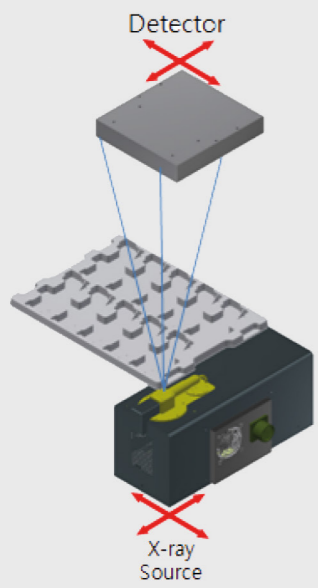

X-eye 6100

Obtain image by moving Object

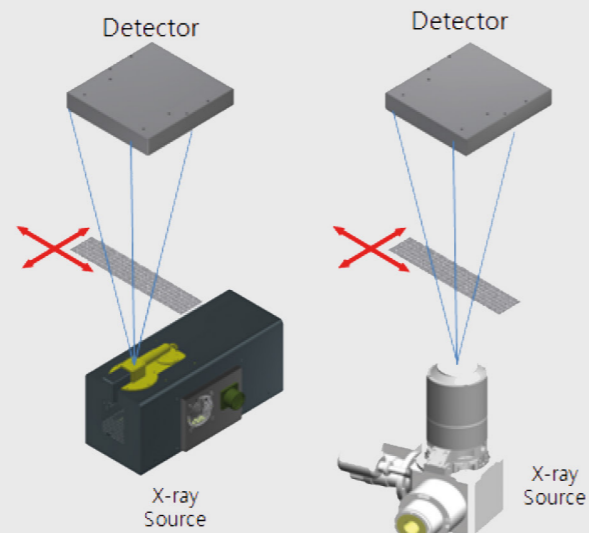

X-eye 6200



X-eye 6000



X-eye 6300

X-eye 6300

Automatically inspects the defects of products in customer's line with high-speed 3D CT tomography. Able to inspect every defects of Double-sided PCBA & BGA mounted components precisely by solving overlapped X-ray image issue. Inspection speed of 3 sec/1FOV from loading to automatic Good / NG judgement.



High speed 3D In-Line Inspection System (~4.3 sec/FOV)

Best Solution for both-side layered PCB

Various defects detectable - BGA, Chip component and etc.

General Product Features

X-ray Tube	160kV / 500μA
Min Resolution	0.8 ~ 15μm
Table Size	Max 330x250mm, Min 50x50mm
Detector	12 inch FPXD
Inspection Object	BGA, Through Hole, Chip, QFN, QFP
Defect Types	PoP, BGA, Connector, Though Hole, Component
Dimension	1,360(W) x 1,880(D) x 1,700(H)mm / 4,200kg

X-ray image

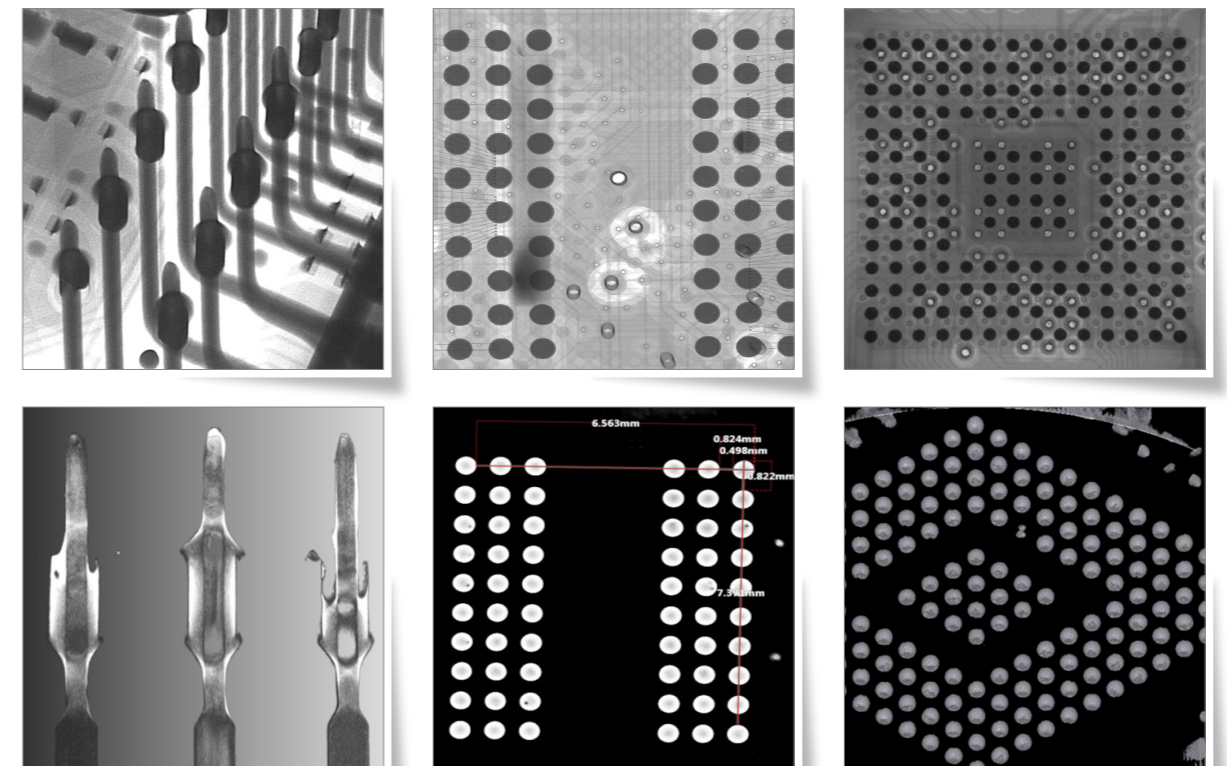

Image Comparison regarding Mechanism

Competitors(Closed tube, Step Scan)

10 sec, 32 image
45 degree

4 sec, 120 image
70 degree

Simulation Phantom

Simulation Result

SEC-Nano Pulse Beam X-ray

High-Speed & High Quality CT Auto Inspection

H&H Mechanism

Image Preprocessing
Image Sinogram
FFT with Image
Convolution with Filter
Inverse FFT
weighted Back Projection

3D Reconstruction

High-speed Reconstruction by GPU parallel calculation

Applied marble frame

Excellent hardness + excellent anti-vibration

Limited Angle Artifacts

Angle Artifacts decrease according to **Detector Tilt** angle
Apply 60° or 70° regarding the volume comes into **Detector**

30° 40°
60° 50°

3D Auto Inspection

Extract longitudinal section and cross-section at the volume with no Angle Artifacts
Detect various defects as Void, Short, Big ball, small ball

Normal E-beam(continuous) type

E-Beam Target X-ray

E-Beam pulse type

E-Beam Target X-ray

Continue X-ray tube
Afterimage occurred

Pulse X-ray Tube
Afterimage removed

Hybrid Open Tube

Best resolution of 0.8 μ m Focal spot
Realize **Pulse beam** - Reduce **damage** and remove **CT afterimage**

Report

Record result of auto inspection

X-eye 6200

Automatically In-Line inspect Solder Joint defects of PCBA, and other defects on Hidden Components. Able to judge Good / NG fast with inspection speed of 0.5 sec/FOV and the program can set ROIs conveniently. Performing X-ray inspection in various production site, integrated with other manufacturing equipments

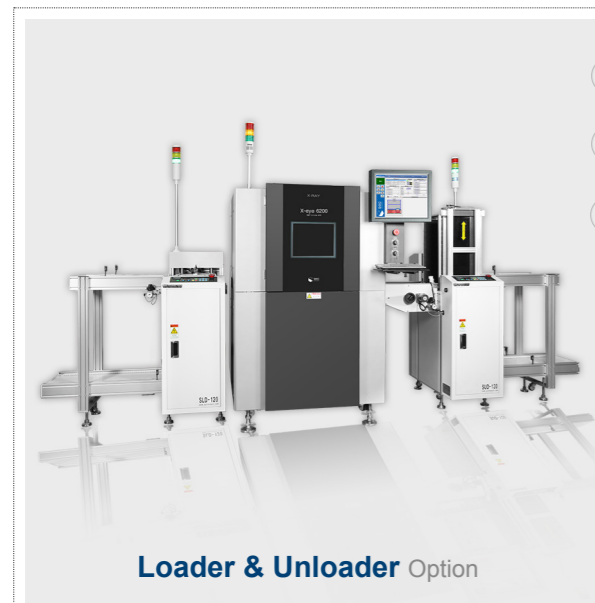

Loader & Unloader Option

High speed 2D In-Line Inspection System (0.5 sec/FOV)

Various defect inspection - BGA, Chip, QFN, QFP etc

WAXI : Wire Automatic X-ray Inspection Detection of wire defects possible (Shorts, sweep, missing, etc)

General Product Features	
X-ray Tube	160kV / 500μA (Option 130kV / 300μA)
Min Resolution	0.8 ~ 15μm
Table Size	Max 330 x 250mm, Min 50 x 50mm
Detector	5 inch FPXD
Inspection Object	BGA, Chip, QFN, QFP, Wire Bonding
Defect Types	BGA : Short, Bridging, Void Chip : Manhattan, Miss align, Short Wire Bonding : Sweep, Broken, Double Bonding, Missing
Dimension	1,460(W) x 1,640(D) x 1,780(H)mm / 2,500kg

X-ray image

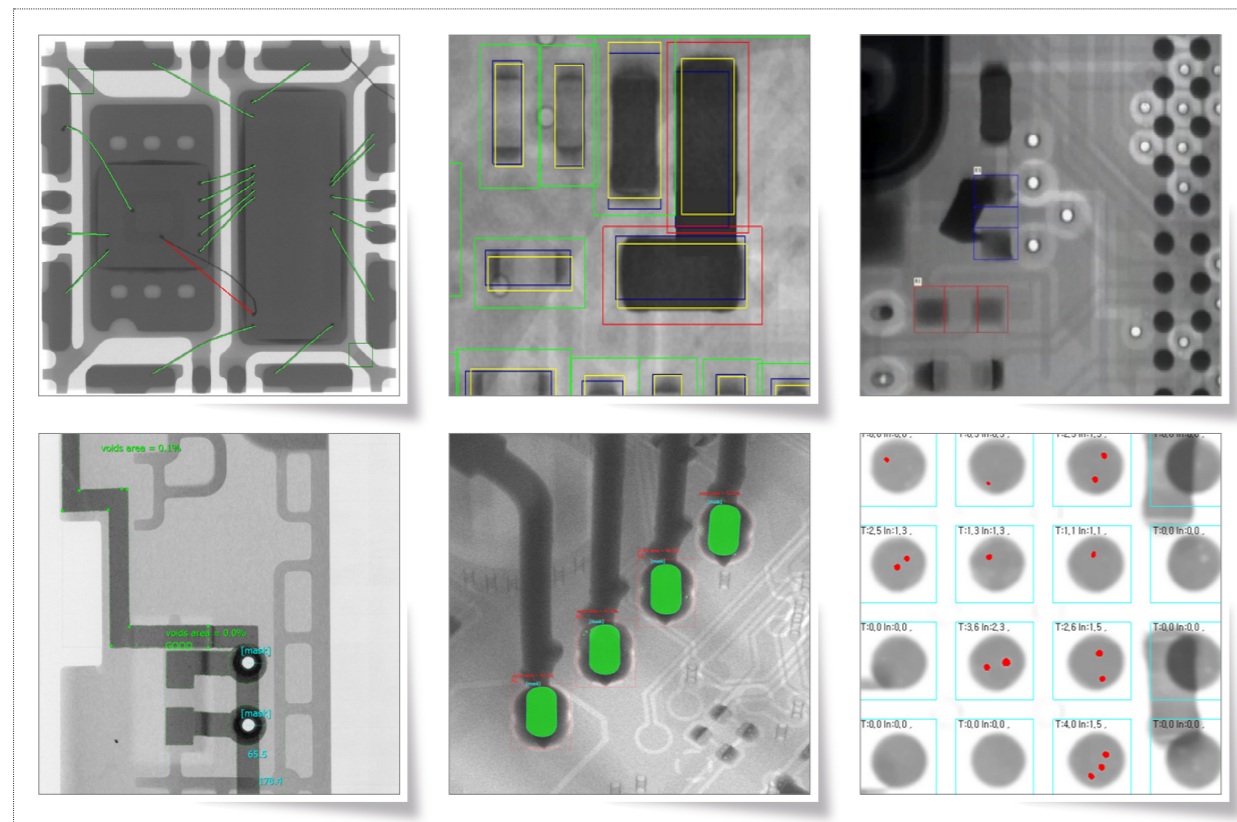

X-eye 6100

Automatically In-Line inspect Solder Joint defects of PCBA, and other defects on Hidden Components. Able to be customized regarding Application by users setting ROIs. Especially, Area type image scanning can gain high resolution results fast.

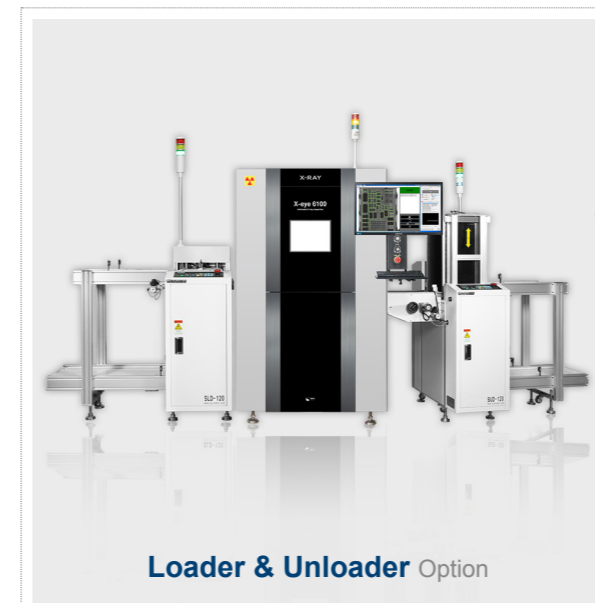

Loader & Unloader Option

High speed 2D In-Line Inspection System (0.5 sec/FOV)

Various defect inspection - BGA, Chip, QFN, QFP etc

WAXI : Wire Automatic X-ray Inspection Detection of wire defects possible (Shorts, sweep, missing, etc)

General Product Features	
X-ray Tube	100kV / 200μA
Min Resolution	5μm
Table Size	400 x 400mm
Detector	5 inch FPXD
Inspection Object	BGA, Chip, QFN, QFP, Wire Bonding
Defect Types	BGA : Short, Bridging, Void Chip : Manhattan, Miss align, Short
Dimension	1,020(W) x 1,350(D) x 1,720(H)mm / 1,500kg

X-ray image

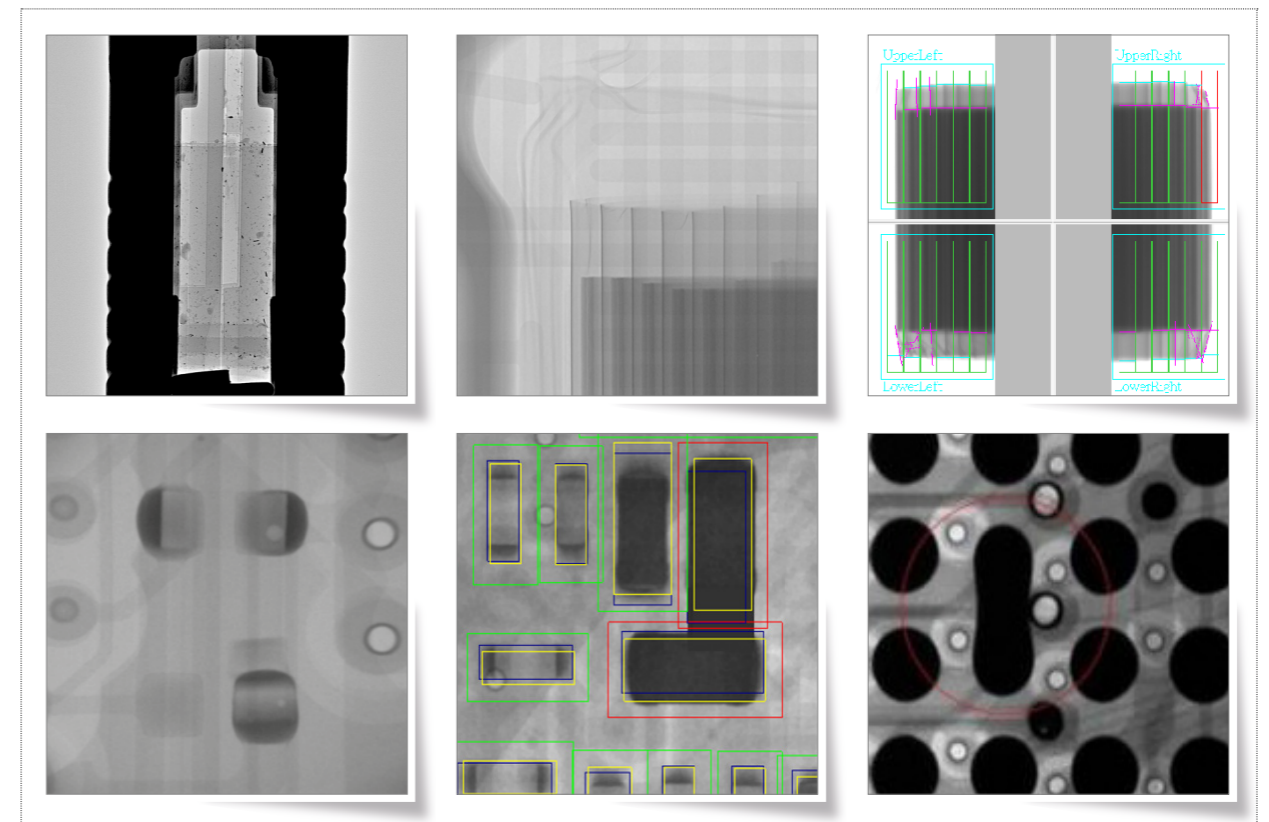

X-eye NF120

Nano-focus Tube of 200 nano resolution is installed which is specialized for Semiconductor Packaging, Wafer Level Packaging(WLP) requiring detection of Sub-micron defect. Able to trace and inspect defected area precisely by precise movement of axis with Anti-vibration table. Tomography is available if 3D CT module is added and Wafer Bump Automatic Inspection is available from loading to inspection with wafer handler systems.



Non-destructive analysis system for Wafer Level Packaging

High resolution image with Dual Type CTs

TSV, Micro Bump, Pattern

General Product Features	
X-ray Tube	120kV / 200μA
Min Resolution	0.2μm
Table Size	12 inch Wafer
AXIS	X, Y, Z Tilt (70°),R
Detector	6 inch FPXD
CT Scan Method	Oblique CT / Cone beam CT
Dimension	2,380(W) x 1,450(D) x 2,120(H)mm / 7,000kg

X-ray image

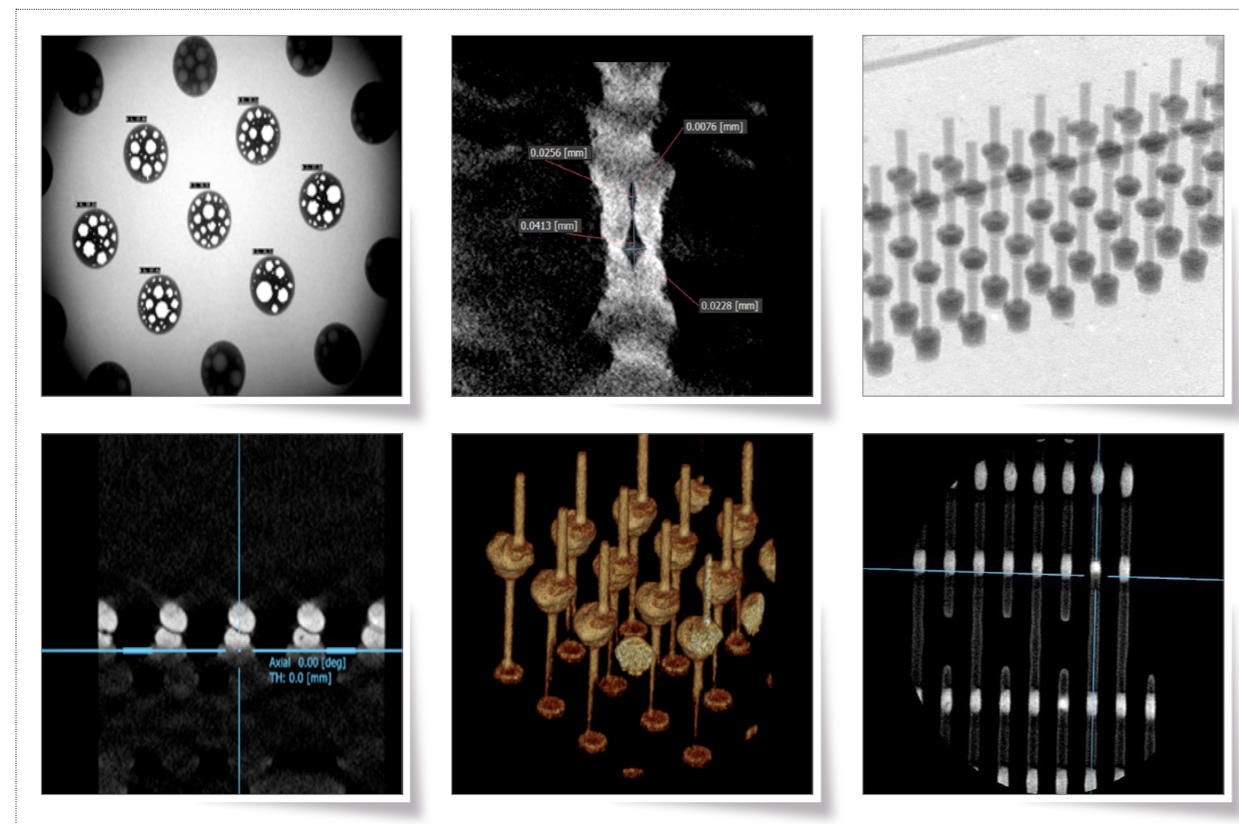

X-eye 6000POP

3D automatic X-ray inspection system for POP(Package on Package), having the latest semiconductor layering technology. From loading to judgement of NG / Good & sorting out of POP products would be made automatically. And results would be saved into basic data based to help SPC. It has the fastest inspection speed of 2.5 sec/FOV.



3D In-Line Inspection System for POP packages

Good-NG analysis of interconnection using **3D CT**

Detection speed : **Max. 2.5 sec/unit**

General Product Features	
X-ray Tube	130kV / 200μA
Min Resolution	6 ~ 15μm
Detector	12 inch FPXD
Chip Size	Max 22 x 22mm, Min 8 x 6mm
Defect Types	Non-wet, Open, Short, Big / Small ball
Dimension	3,080(W) x 1,730(D) x 1,920(H)mm / 4,800kg

X-ray image

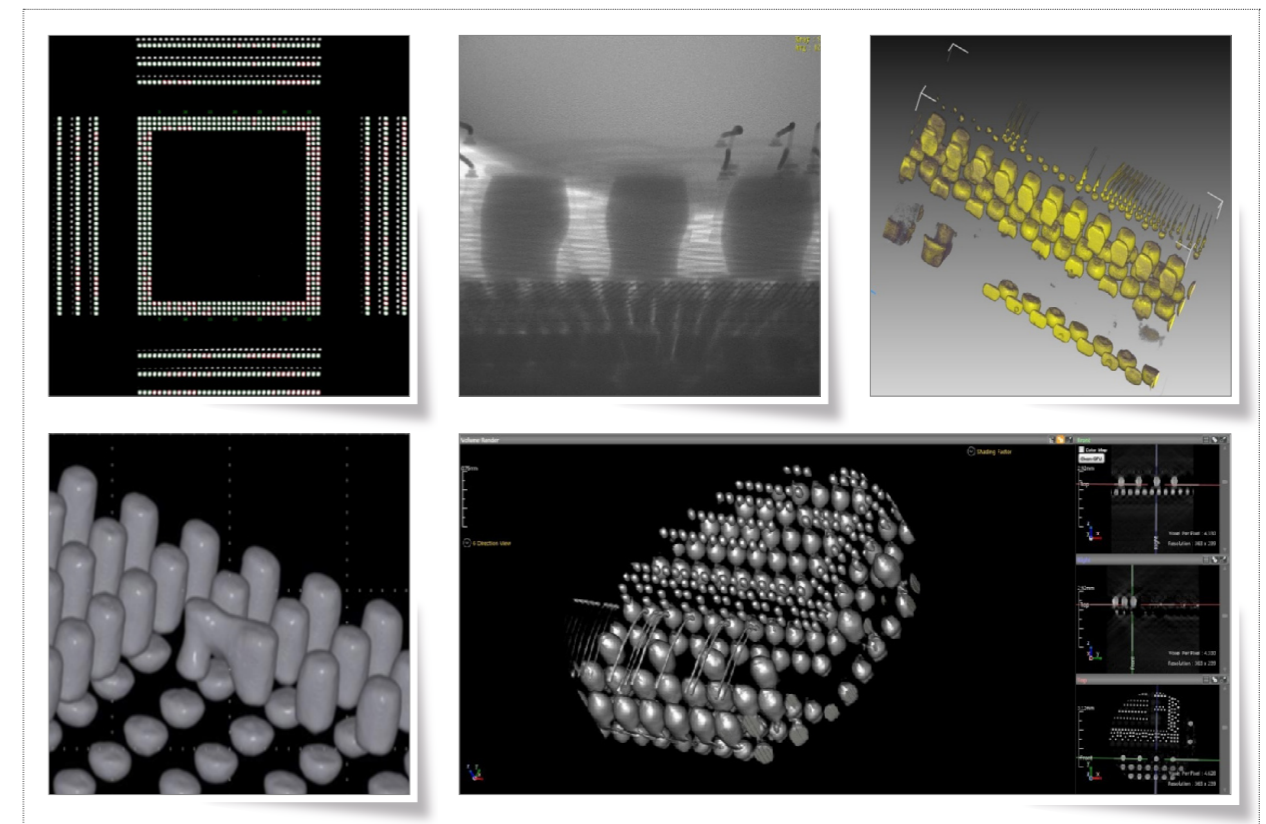

X-eye 7000B

Appropriate for the inspection of medium·large size components and detection of surface structure and defects (inside voids and cracks etc). Due to high-energy, high-power Micro-focus X-ray Open Tube, maintenance cost's significantly reduced and long-term use possible with only replacing consumables. Customization is available with selecting main parts by customers depends on their needs for size and material.

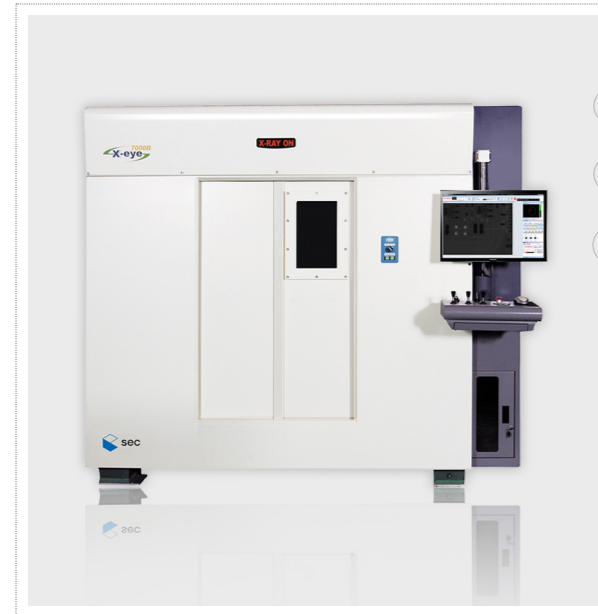

Non-destructive analysis system for the large-size components

Various option for X-ray Tubes and Detectors

High power X-ray tube option

General Product Features	
X-ray Tube	160kV / 3,000μA
Min Resolution	6μm
Table Size	Ø 600mm x 900Lmm
AXIS	X, Y, Z, R
Detector	12 inch FPXD
CT Scan Method	Cone beam CT
Dimension	2,560(W) x 1,900(D) x 2,120(H)mm / 5,000kg

X-ray image

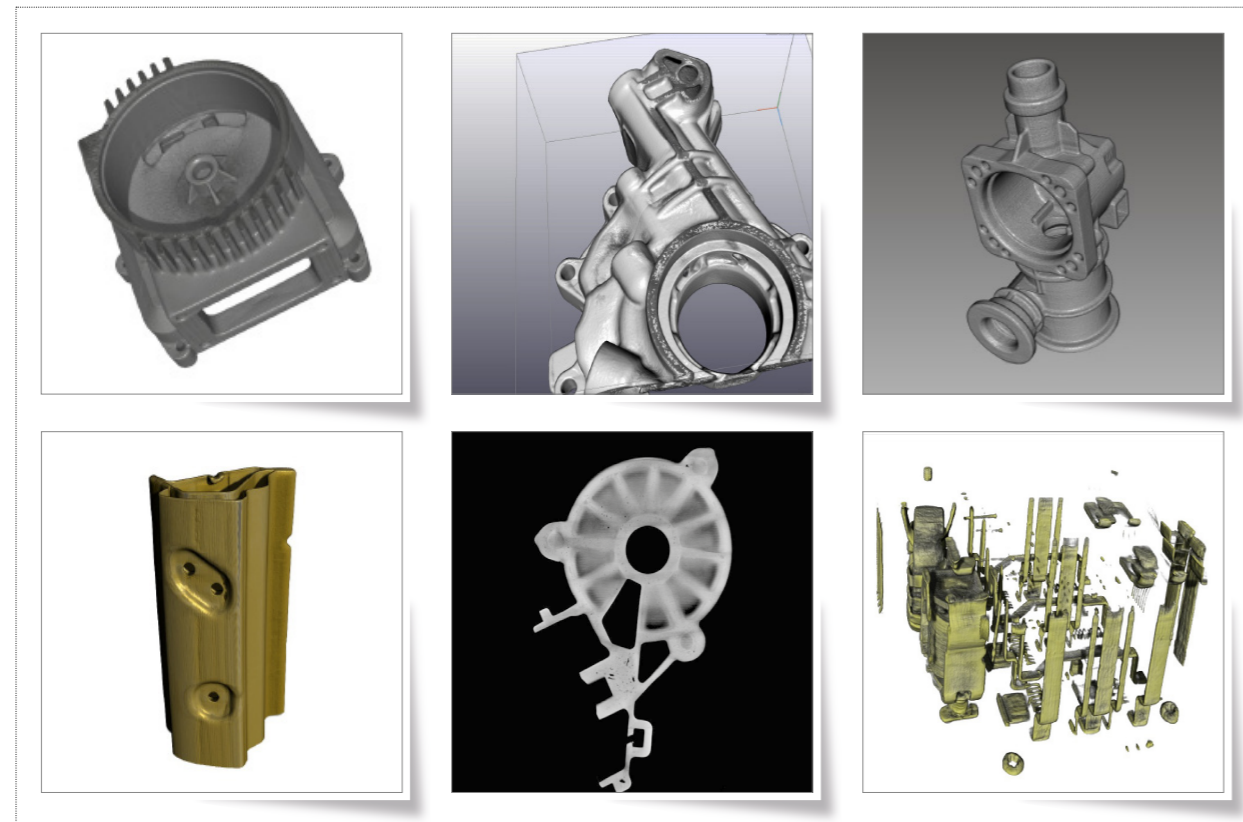

X-eye 7000BS

Appropriate for medium·large size component inspection and detecting surface structure and defects(inside voids and cracks etc). Due to high-energy, high-power Micro-focus X-ray Open Tube, maintenance cost's reduced significantly and enables long-term use with only replacing consumables. Customization is available with selecting main parts by customers depends on their needs for size and material.

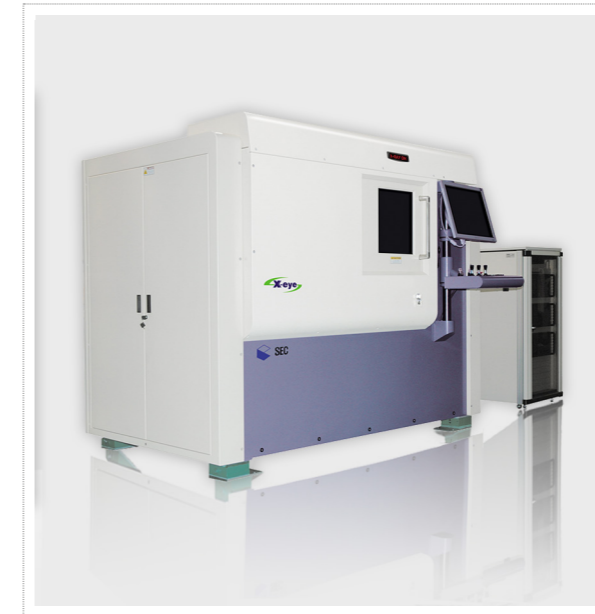

Non-destructive analysis system for small & medium sized components

High-resolution images with Open Tube

Enable to get CT images in very sort time using **continuous scan** (5 min)

General Product Features	
X-ray Tube	160kV / 1,000μA
Min Resolution	6μm
Table Size	Ø 300mm x 300Lmm
AXIS	X, Y, Z, R
Detector	6 inch FPXD
CT Scan Method	Cone beam CT
Dimension	1,840(W) x 1,500(D) x 1,780(H)mm / 2,500kg

X-ray image



X-eye PCT

Inspection system for 3D X-ray CT able to analyze defected area precisely by precise movement of axis with high polished Anti-vibration table. High-power X-ray Tube of max. 450kV and large area Flat Panel Detector of max. 16 inches can be installed depending on the sample. Customized 3D CT equipment is available with selecting main parts by customers depends on thier needs for size and material.



Enable control of precise movement of axis with **Anti-vibration table**

Various options for High power X-ray Tubes

Enable inspection of **large sized products**

General Product Features	
X-ray Tube	225kV / 3,000μA
Min Resolution	6μm
Table Size	Ø 600mm x 900Lmm
AXIS	X, X-d, Y-t, Y-d, Z, R
Detector	16 inch FPXD
CT Scan Method	Cone beam CT
Dimension	2,680(W) x 1,570(D) x 2,330(H)mm / 8,000kg

X-ray image

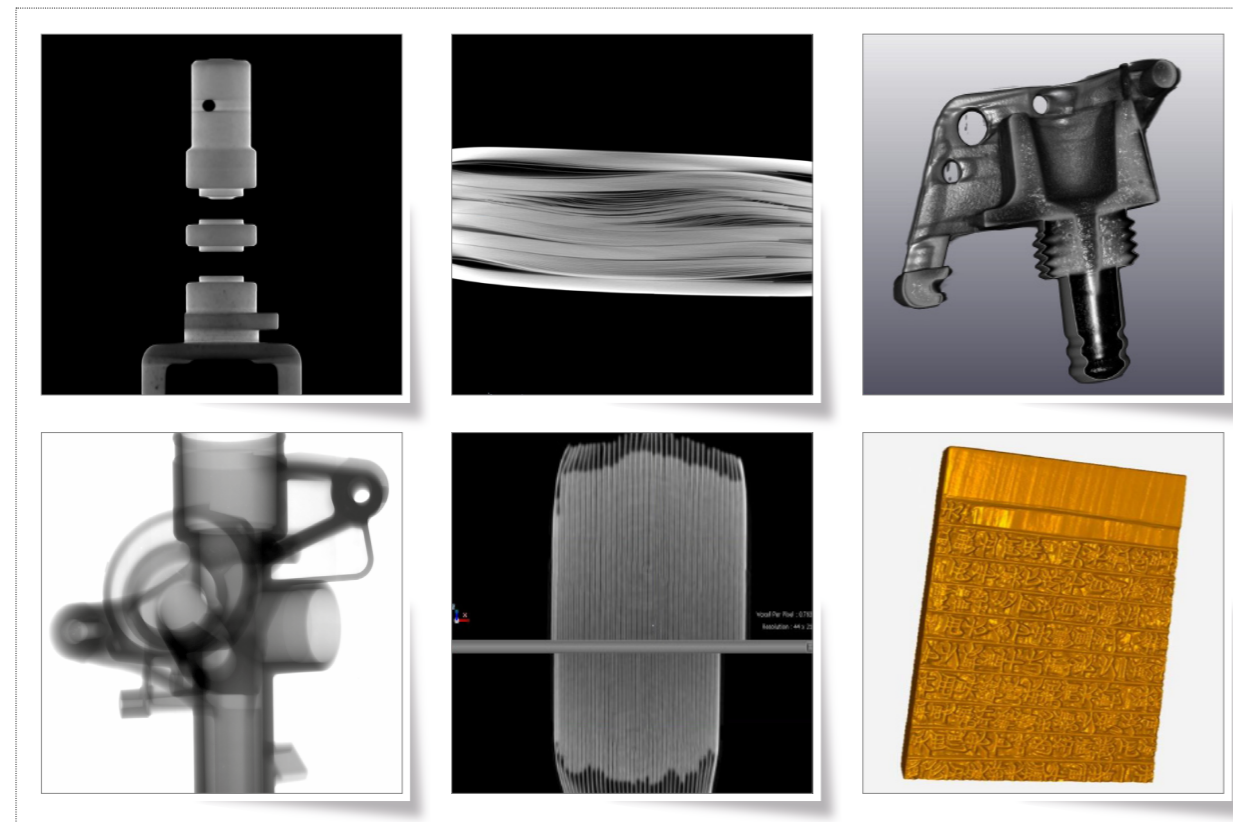

X-eye 4000A

Inspection system for counting the amount of Reel and Chip according to various size and type. Non-destructive inspection system which counts the amount within 9 sec and shows the result.



Inspection speed : **9 sec**

Counting **Chips and nonstandard components in reel**

No need additional **Inspection Parameter Setting**

General Product Features	
X-ray Tube	130kV / 200μA
Min Resolution	6μm (Option 0.4mm)
Table Size	MAX Ø 400
Z-AXIS	Z-axis Auto Moving
Detector	17 inch FPXD
Dimension	1,400(W) x 1,240(D) x 810(H)mm / 650kg
Cycle Time	9 sec (standard : Ø 180 Reel)
Counting Accuracy	>99.9%
Scan Reel Diameter	Max. Ø 400

X-eye 9000 Series

Auto In-Line Inspection System for secondary battery.

Enable to inspect secondary battery Cell high speed (max. 180 ppm) by battery plate inspection (Angled-shape, circle-shape, pouch-shape)



In-Line Inspection System for **secondary battery total inspection**

Battery plate inspection
(Angled-shape, circle-shape, pouch-shape)

Max. 180 ppm inspection available

General Product Features	
X-ray Tube	100V / 200μA
Min Resolution	5μm
Inspection Ability	120ppm, 150ppm, 180ppm
System	Conveyor / Index / Pick & Place Type Loading
Dimension	1,800(W) x 1,560(D) x 2,070(H)mm / 5,000kg

X-ray Application & Image

SMT

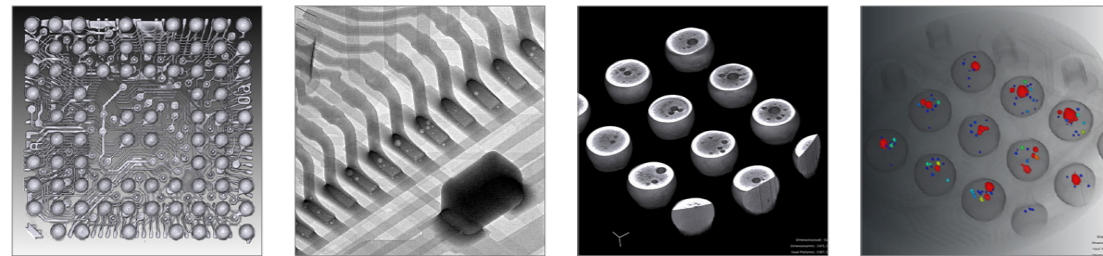

PCB

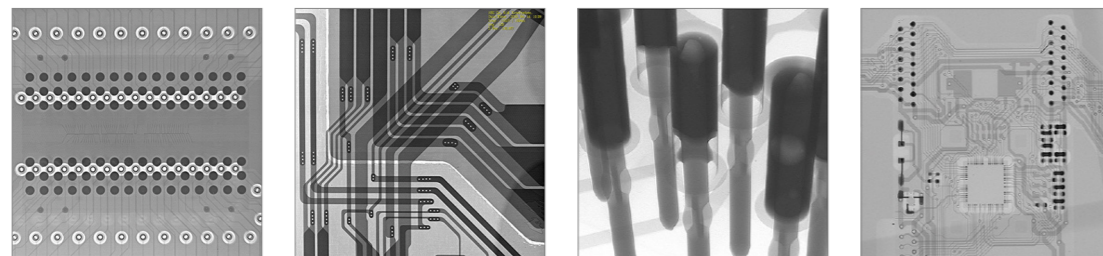

PKG

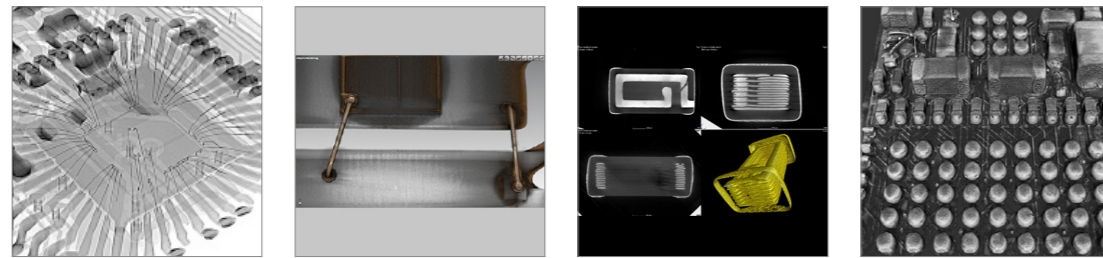

Wafer

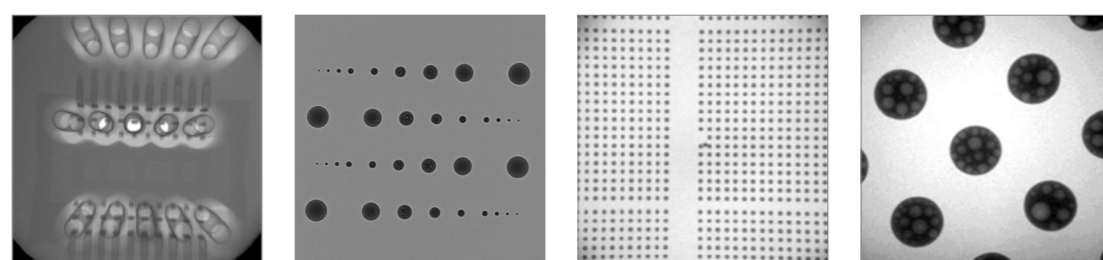

LED

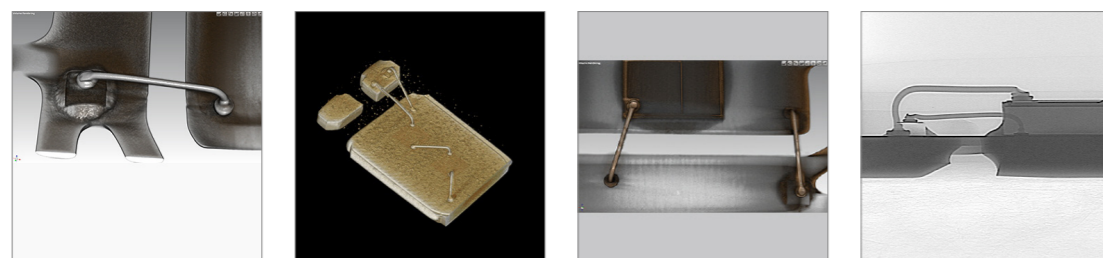

Casting

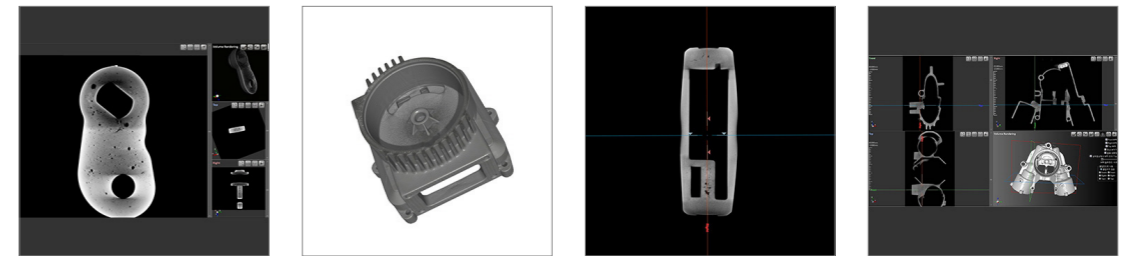

Electronics



Battery

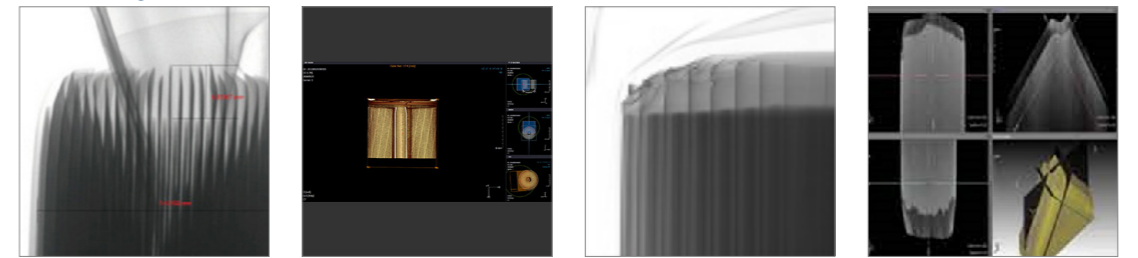

Harness

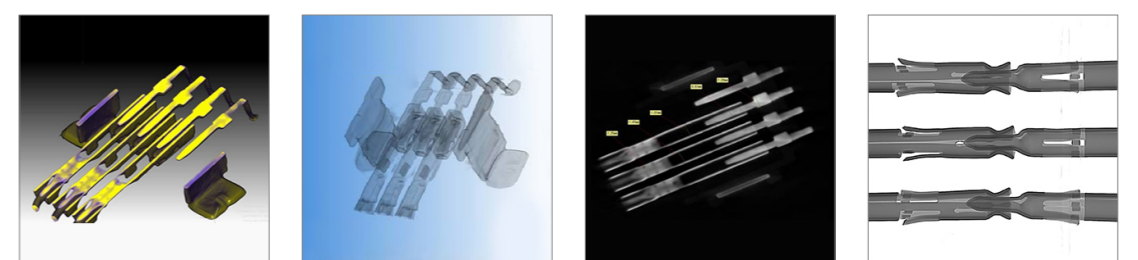

Cultural Assets / Fire Analysis

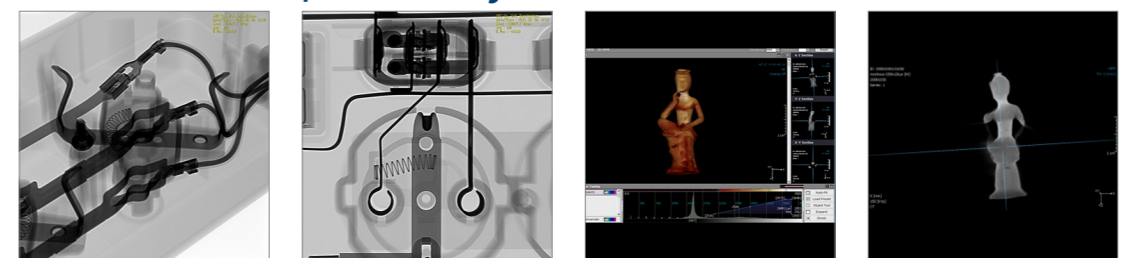

Distribution

Branch Office in China (Shenzhen), 24 Distributors in 35 countries



	KOREA
	JAPAN
	CHINA
	TAIWAN
	HUNGARY
	FRANCE
	GERMANY
	U.K

	VIETNAM
	PHILIPPINES
	MALAYSIA
	INDONESIA
	ITALY
	SPAIN
	CANADA
	U.S

	INDIA
	AUSTRALIA
	RUSSIA
	ISRAEL
	MEXICO
	BRAZIL
	SINGAPORE
	THAILAND

